

Empowered by Innovation



Fault Tolerant Server

NEC Express5800/ft series

The ultimate choice for business continuity
NEC Express5800 fault tolerant servers



Fully redundant components are highly resistant to failures. High-availability servers for nonstop systems NEC Express5800/ft series

A single moment of downtime is not an option in today's business environment — a single server failure could affect a company's system as a whole, resulting in enormous loss of business opportunities. System administrators, therefore, focus their efforts on minimizing risk of downtime and keeping their systems up and running. Equipped with fully redundant components designed to run in lockstep, the Intel® architecture-based NEC Express5800/ft series fault tolerant servers address planned and unplanned downtime and deliver exceptional availability.

Hardware Redundancy in All Primary Components



R320b-M4 (Front)

Fully redundant by dual modular architecture

Dual modular redundant design



Rear

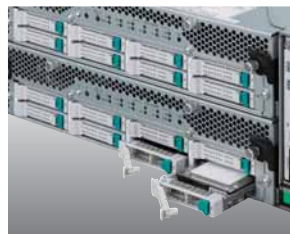

Disk drives are built into each module. Rapid Disk Resync (RDR) ensures disk redundancy.

CPU

Powered by Intel® Xeon® processor 5600 or 5500 series with Intel QuickPath Architecture



LAN/PCI



Each module provides two LAN ports and four PCI-Express slots.

CPU/IO module

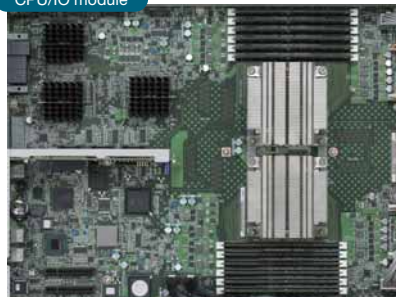

CPU/IO modules, which include CPU, memory and PCI slots, are fully hot-swappable.

Memory



Up to 96GB of DDR3 DIMMs



Continuous Processing

High-availability by redundancy chipset GeminiEngine™

The redundancy chipset GeminiEngine™ is a chipset specially engineered for transparent failover and system integrity. In NEC's FT servers, main hardware components are replicated and modularized for full hardware redundancy. The redundancy chipset controls these redundant modules to process the same instructions simultaneously, delivering so-called "lockstep" processing. When a fault is detected, the faulty module is isolated and is allowed to be removed while the other remains online and continues operation. After replacement, the pair modules are automatically synchronized and resume normal operation. Through the whole process, the redundancy chipset ensures continuous processing without any interruption or loss of data.

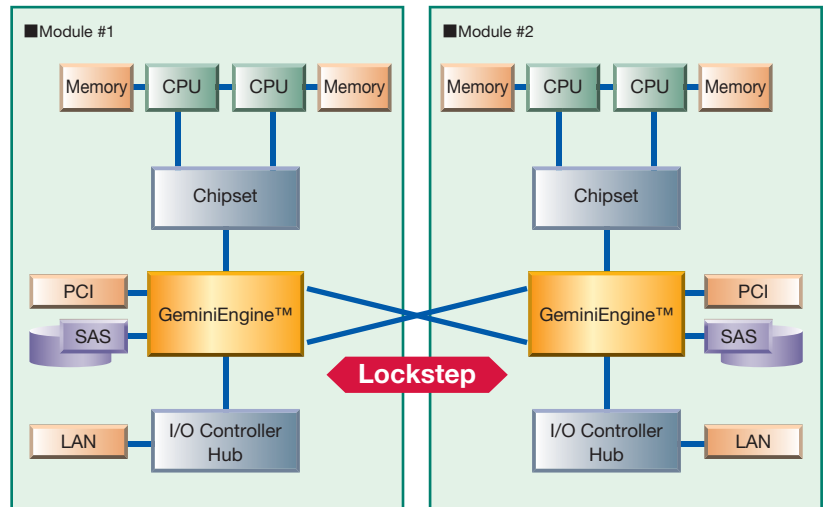

Easy to Deploy

Seamless deployment and operation—no complexities

The NEC Express5800/ft series servers, though replicated in architecture, perform as single servers running a single operating system*, allowing configuration without any special considerations for the fault tolerant capabilities. Its user-transparent features eliminate the need to modify any middleware or applications. System availability is significantly improved just by replacing general servers with NEC FT servers.

*: VMware models can run multiple operating systems by virtualization.

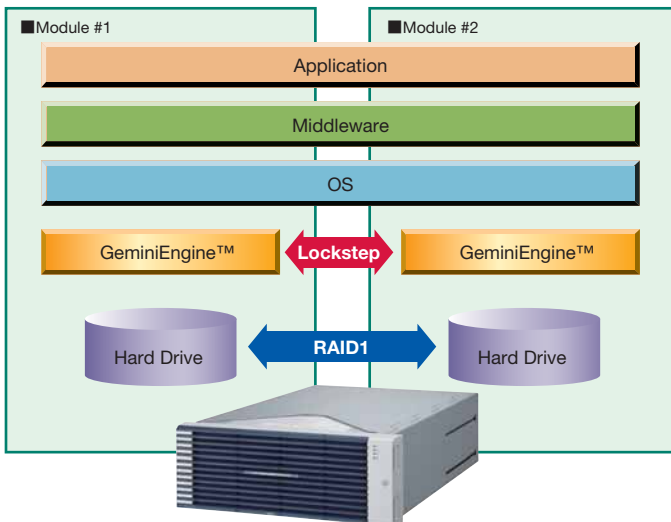

Note: The NEC Express5800/ft series servers are intended to enhance hardware fault tolerance by replicating main hardware components and do not ensure fault tolerance for operating systems and software applications installed. To secure software fault tolerance, customers are required to take necessary preventive measures as exercised for general servers.

- FT servers provide a single-server view, free of any special considerations for the redundant architecture.
- Most applications are compatible and do not need special modification.
- FT servers do not require special administrative resources and allow easy low-cost management.

Simplified Management

The NEC Express5800/ft series servers feature LED status indicators allowing instant identification of failed components. This feature is controlled by EXPRESSSCOPE Engine2, an integrated baseboard management controller. In tandem with the bundled NEC ESM PRO Agent monitoring software that alerts failures to the management PC, it allows centralized remote management of the hardware and power supply.



EXPRESSSCOPE
LED indicators allow users to visually identify failed components

Lower TCO

The FT server can deliver a lower total cost of ownership over the life of a server as compared to alternative high availability solutions, such as software clusters. To run in redundant mode, the FT server only requires one copy of the operating system and application software license and no professional services to setup or configure the server. It's simple to setup, simple to use, and simple to manage.

Fully-Redundant and Hot-Swappable Modules Achieve Continuous Availability

Minimum Downtime

Normal operation

Powered by GeminiEngine™, replicated modules run in lockstep as one logical server.

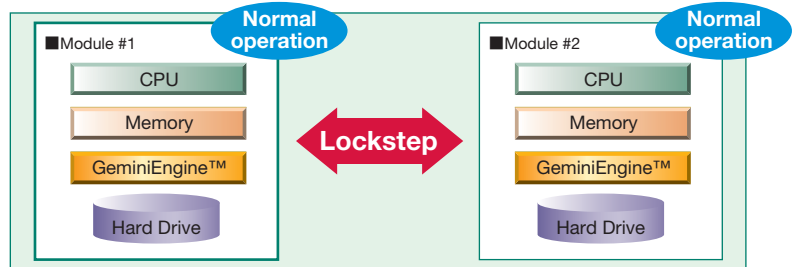

Fault detection

In case of hardware malfunction, the faulty module is instantly isolated and the server continues operation on the other healthy module. The hot-swappable modules enable repair and replacement without interrupting processing.

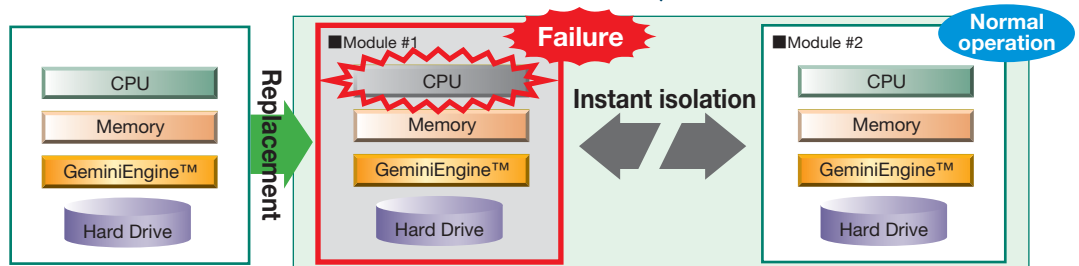

Back to normal operation

Following the repair or replacement, both modules are automatically resynchronized and resume normal operation. There is no need to stop/re-boot the system, and both the OS and the applications are unaffected, achieving continuous processing throughout the whole process.

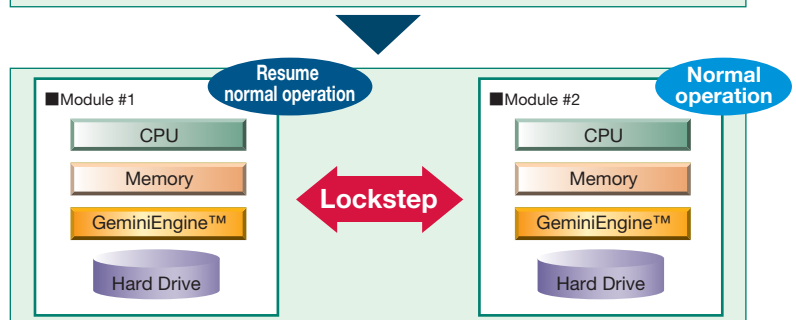

High-Availability Technology

Rapid Disk Resync (RDR)

The Rapid Disk Resync (RDR) redundancy software is used for hard disk drive synchronization, ensuring excellent reliability during normal operation. In addition, after a hard drive has stopped as a result of a failure, RDR copies only data changes to update it, thereby minimizing the time that the system runs with only one of the redundant disk drive modules.

(RDR is available only with the Windows models)

EXPRESSCLUSTER X SingleServerSafe

EXPRESSCLUSTER X SingleServerSafe is optional software to enhance software availability, providing 24 x 7 monitoring of server and software status. In the event of a failure, the application or OS is automatically shutdown and restarted to swiftly resume operation.

Active Upgrade™

The Active Upgrade™ feature minimizes the planned downtime required to install security patches and software upgrades. The synchronized modules are separated and patches are applied to one module while the other remains online and continues operations. The operating module is then switched, keeping downtime to a minimum.

(Active Upgrade™ is available only with the Windows models)

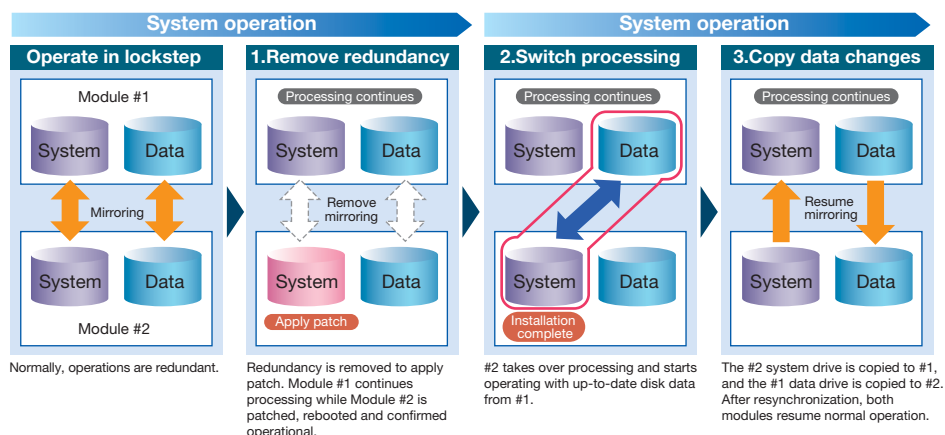

For More Availability and Reliability

A Reliable Platform for Virtualization

FT Servers + VMware vSphere™ 4 / Hyper-V™ 2.0

Server consolidation with virtualization can significantly lower the TCO by reducing distributed servers and much of the maintenance related workloads and costs. By supporting VMware vSphere 4 and Microsoft® Windows Server® 2008 R2 Enterprise Hyper-V 2.0, NEC Express5800/ft series servers provide a virtualization platform of utmost reliability and availability.

In a virtualized environment, multiple virtual servers reside on a single physical server and its downtime can cause unprecedented damage. NEC FT servers reduce these costly risks by its fully redundant hardware and ensure continuous operation of your virtualized setting.

- Consolidate multiple existing systems on one FT server
- Minimize downtime of multiple virtual servers in the event of hardware failure

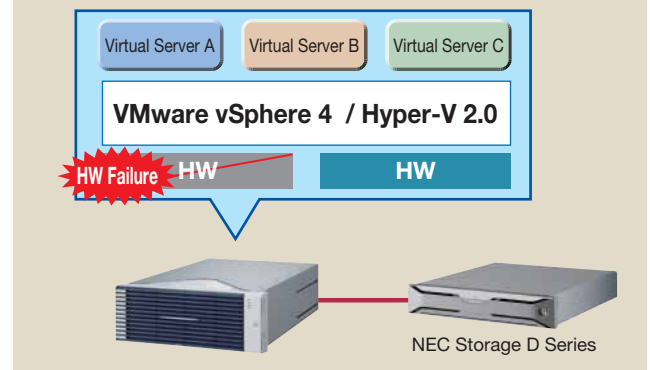

A High-Availability Database System

FT Servers + Large Storage Capacity

The NEC Express5800/ft series support NEC's SAN-compatible disk array devices NEC Storage D Series for catering to specific capacity needs. The redundant data path between the FT server and storage ensures instant operation switching and continuous availability in the event of a failure, regardless of where the malfunction occurs. This solution is ideal for customer-facing, production and sales management systems, electronic patient record and knowledge management systems, and other environments requiring large volume, high availability and high-speed response.

- Hardware redundancy extends to the connection path
- Redundancy control software provides immediate switching in the event of a path or FC controller failure

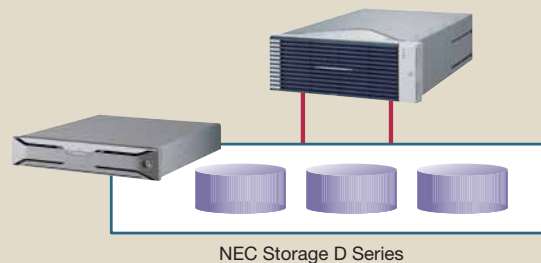

Ensuring Software Fault Tolerance for Higher Availability

FT Server Clustering

Cluster systems utilizing NEC FT servers provide continuous availability in the event of both software and hardware failures. NEC's FT servers and EXPRESSCLUSTER X clustering software create a reliable clustering system with shared disks.* When a hardware component fails, the NEC FT server isolates the faulty module and continues to operate. If a software failure interrupts server operation, the faulty server fails over to one in another node and continues processing. Compared to the general IA server clusters, the FT server cluster delivers superior robustness and availability through eliminating system downtime caused by switching between nodes in the event of a hardware failure. The FT server cluster is ideal for mission-critical systems that require higher availability and reliability.

- Each node runs different applications
- A node failover ensures system continuity in the event of software failure

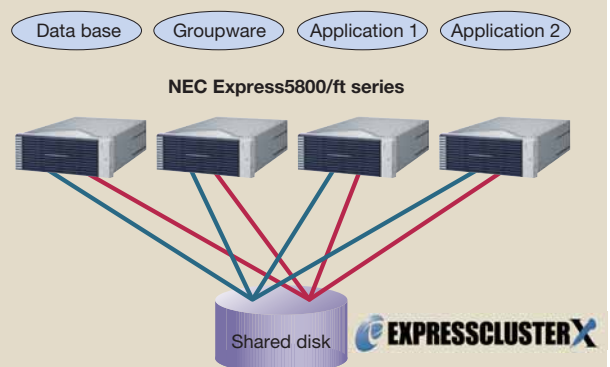

*: only compatible with NEC Storage

Lineup

Windows Models

Intel® Xeon® processor 5600 and 5500 series deliver high performance processing that stands up to heavily-loaded operations



NEC Express5800/R320b-M4

- Intel® Xeon® processor X5670 (two sockets)
- Up to 96GB, DDR3 Registered DIMM with ECC
- Up to 4.8TB SAS internal hard disk drives
- 4 x PCI Express
- Microsoft® Windows Server® 2008 R2 Enterprise
- Active Upgrade™, Rapid Disk Resync

NEC Express5800/R320a-M4

- Intel® Xeon® processor X5570 (two sockets)
- Up to 48GB, DDR3 Registered DIMM with ECC
- Up to 4.8TB SAS internal hard disk drives
- 4 x PCI Express
- Microsoft® Windows Server® 2008 Enterprise (32bit) SP2
- Active Upgrade™, Rapid Disk Resync

NEC Express5800/R320a-E4

- Intel® Xeon® processor E5504 (two sockets)
- Up to 48GB*/96GB, DDR3 Registered DIMM with ECC
- Up to 4.8TB SAS internal hard disk drives
- 2 x PCI Express
- Microsoft® Windows Server® 2008 Enterprise (32bit) SP2
- Microsoft® Windows Server® 2008 R2 Enterprise
- Active Upgrade™, Rapid Disk Resync

*: For Microsoft® Windows Server 2008 Enterprise (32bit) model: up to 48GB memory

Red Hat Enterprise Linux Models

Compatibility with Red Hat® Enterprise Linux® 5.5 (EM64T) makes it possible to build flexible systems utilizing OSS.



NEC Express5800/R320b-M4

- Intel® Xeon® processor X5670 (two sockets)
- Up to 96GB, DDR3 Registered DIMM with ECC
- Up to 4.8TB SAS internal hard disk drives
- 4 x PCI Express
- Red Hat® Enterprise Linux® 5.5 (EM64T)*

NEC Express5800/R320a-E4

- Intel® Xeon® processor E5504 (two sockets)
- Up to 96GB, DDR3 Registered DIMM with ECC
- Up to 4.8TB SAS internal hard disk drives
- 2 x PCI Express
- Red Hat® Enterprise Linux® 5.5 (EM64T)*

*: Xen/KVM (Kernel-based Virtual Machine) is not supported

VMware Models

Compatibility with VMware vSphere™ 4 virtualization software provides high reliability. Ideal for consolidating mission-critical systems.



NEC Express5800/R320a-M4

- Intel® Xeon® processor X5570 (two sockets)
- Up to 96GB, DDR3 Registered DIMM with ECC
- Up to 2.4TB SAS internal hard disk drives
- 4 x PCI Express
- VMware vSphere™ 4 Update2

NEC Express5800/R320a-E4

- Intel® Xeon® processor E5504 (two sockets)
- Up to 96GB, DDR3 Registered DIMM with ECC
- Up to 2.4TB SAS internal hard disk drives
- 2 x PCI Express
- VMware vSphere™ 4 Update2

Install rack models in a tower enclosure Tower Conversion Kit

The tower configuration is ideal for customers considering a single server installed in an office environment. Use the Tower Conversion Kit to install ft series as tower models.



Internal view
(front bezel opened)

| Model | Windows model | | | | Linux model | | VMware model | |
|------------------------------------|--|--|---|--|--|--|--|--|
| | NEC Express5800/ R320a-E4 | NEC Express5800/ R320b-M4 | NEC Express5800/ R320a-E4 | NEC Express5800/ R320a-M4 | NEC Express5800/ R320a-E4 | NEC Express5800/ R320b-M4 | NEC Express5800/ R320a-E4 | NEC Express5800/ R320a-M4 |
| Form Factor | 4U rack-mountable | | | | | | | |
| Processor | Intel® Xeon® processor E5504 | Intel® Xeon® processor X5670 | Intel® Xeon® processor E5504 | Intel® Xeon® processor X5570 | Intel® Xeon® processor E5504 | Intel® Xeon® processor X5670 | Intel® Xeon® processor E5504 | Intel® Xeon® processor X5570 |
| Clock Speed | 2GHz | 2.93GHz | 2GHz | 2.93GHz | 2GHz | 2.93GHz | 2GHz | 2.93GHz |
| L3 cache | 4MB | 12MB | 4MB | 8MB | 4MB | 12MB | 4MB | 8MB |
| Core / Thread | 4C / 4T | 6C/12T | 4C / 4T | 4C / 8T | 4C / 4T | 6C / 12T | 4C / 4T | 4C / 8T |
| Logical Processors | 1 (std.) - 2 (max.) | | | | | | | |
| Chipset | Intel® 5500 with GeminiEngine™ | | | | | | | |
| Memory Type | DDR3 SDRAM DIMM with ECC, Registered | | | | | | | |
| Logical Max. Memory | 96GB (8GB x 12) | | 48GB (4GB x 12) | | 96GB (8GB x 12) | | | |
| Memory Clock | 800MHz | 1333MHz | 800MHz | 1066MHz | 800MHz | 1333MHz | 800MHz | 1066MHz |
| Storage Logical Max.Capacity | 4.8TB (600GB x 8) | | | | | | 2.4TB (300GB x 8) | |
| I/F and RAID | SAS 3Gb/s, RAID 1 | | | | | | | |
| FDD | Optional *1 | | | | | | | |
| ODD (Logical) | DVD-RAM drive *2 | | | | | | | |
| Device Bay | - | | | | | | | |
| PCI Slots (Logical) | Low profile: PCI Express (x8) x 2*3 | Low profile: PCI Express (x8) x 2*3 Full height: PCI Express (x8) x 2*3 | Low profile: PCI Express (x8) x 2*3 | Low profile: PCI Express (x8) x 2*3 Full height: PCI Express (x8) x 2*3 | Low profile: PCI Express (x8) x 2*3 | Low profile: PCI Express (x8) x 2*3 Full height: PCI Express (x8) x 2*3 | Low profile: PCI Express (x8) x 2*3 | Low profile: PCI Express (x8) x 2*3 Full height: PCI Express (x8) x 2*3 |
| Video RAM | 32MB | | | | | | | |
| Network (Logical) | 1000BASE-T x 2, Management LAN x 1 | | | | | | | |
| External Video Interface | 15-pin mini-D sub x 1 | | | | | | | |
| USB *4 | USB2.0 x 4 | | | | | | | |
| Dimensions (WDH) | 483 x 736 x 178 mm | | | | | | | |
| Weight (max.) | 52Kg | | | | | | | |
| Max. Power Consumption | 1,400VA / 1,390W | | | | | | | |
| Temperature and humidity condition | 10 to 35°C / 20 to 80% (non-condensing) | | | | | | | |
| Software for Availability | Active Upgrade™, Rapid Disk Resync (RDR) | | | | - | | | |
| Support OS | Microsoft® Windows Server® 2008 R2 Enterprise | | Microsoft® Windows Server® 2008 Enterprise (32bit) SP2 | | Red Hat® Enterprise Linux® 5.5 (EM64T)*5 | | VMware vSphere™ 4 Update2 | |

*1 Required for maintenance

*2 DVD: max. X8, CD: max. X24

Writing software is not provided for this drive

*3 Operates at X4 bandwidth

*4 Supports only NEC-authorized keyboard, mouse, floppy disk drive, and KVM switch

*5 Xen/KVM (Kernel-based Virtual Machine) is not supported

| | |
|-----------------------------|---|
| Tower Conversion Kit | 327mm(W) x 804mm(D) x 592mm(H), 27.1kg (including stabilizer) |
|-----------------------------|---|

Note: Specifications are subject to change without notice.

NEC Express5800

<http://www.nec.com/express/>

Copyright © NEC Corporation 2011. All rights reserved.

NEC EXPRESS5800

- Microsoft, Windows Server, and Hyper-V are either registered trademarks or trademarks of Microsoft Corporation in the United States and/or other countries.
- Intel, Intel Logo, Intel Inside, Intel Inside Logo, Xeon, and Xeon Inside are trademarks of Intel Corporation in the U.S. and/or other countries.
- VMware is a registered trademark or trademark of VMware, Inc. in the United States and/or other jurisdictions.
- Red Hat and Red Hat Enterprise Linux are registered trademarks of Red Hat Inc. in the United States and other countries.
- Linux is a registered trademark of Linus Torvalds.
- All other products, brands, or trade names used in this document are trademarks or registered trademarks of their respective holders.
- Specifications are subject to change without notice.

For further information, please contact: